

DP8572A/DP8572AM Real Time Clock (RTC)

General Description

The DP8572A (8572AM—militarized version) is intended for use in microprocessor based systems where information is required for multi-tasking, data logging or general time of day/date information. This device is implemented in low voltage silicon gate microCMOS technology to provide low standby power in battery back-up environments. The circuit's architecture is such that it looks like a contiguous block of memory or I/O ports. The address space is organized as 2 software selectable pages of 32 bytes. This includes the Control Registers, the Clock Counters, the Alarm Compare RAM, and the Time Save RAM. Any of the RAM locations that are not being used for their intended purpose may be used as general purpose CMOS RAM.

Time and date are maintained from 1/100 of a second to year and leap year in a BCD format, 12 or 24 hour modes. Day of week, day of month and day of year counters are provided. Time is controlled by an on-chip crystal oscillator requiring only the addition of the crystal and two capacitors. The choice of crystal frequency is program selectable.

Power failure logic and control functions have been integrated on chip. This logic is used by the RTC to issue a power fail interrupt, and lock out the μ p interface. The time power fails may be logged into RAM automatically when $V_{BB} >$

V_{CC} . Additionally, two supply pins are provided. When $V_{BB} > V_{CC}$, internal circuitry will automatically switch from the main supply to the battery supply. Status bits are provided to indicate initial application of battery power, system power, and low battery detect. (Continued)

Features

- Full function real time clock/calendar
 - 12/24 hour mode timekeeping
 - Day of week and day of years counters
 - Four selectable oscillator frequencies
 - Parallel resonant oscillator
- Power fail features
 - Internal power supply switch to external battery
 - Power Supply Bus glitch protection
 - Automatic log of time into RAM at power failure
- On-chip interrupt structure
 - Periodic, alarm, and power fail interrupts
- Up to 44 bytes of CMOS RAM
- MIL-STD-883C compliant
- SMD #5962-91641-01MJX (future)

Block Diagram

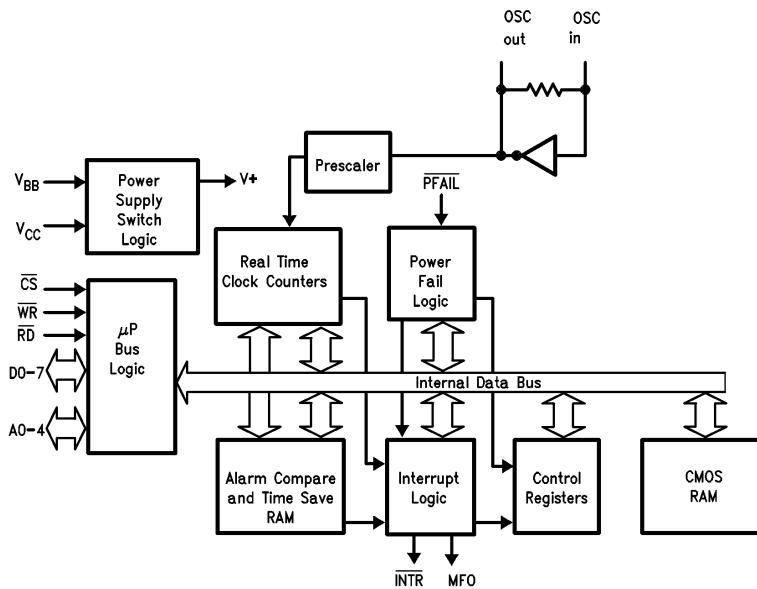

FIGURE 1

TL/F/9980-1

TRI-STATE® is a registered trademark of National Semiconductor Corporation.

8572A

Operation Conditions

Absolute Maximum Ratings (Notes 1 & 2)

Specifications for the 883 version of this product are listed separately.

Supply Voltage (V_{CC})	-0.5V to +7.0V
DC Input Voltage (V_{IN})	-0.5V to $V_{CC} + 0.5V$
DC Output Voltage (V_{OUT})	-0.5V to $V_{CC} + 0.5V$
Storage Temperature Range	-65°C to +150°C
Power Dissipation (PD)	500 mW
Lead Temperature (Soldering, 10 sec.)	260°C

	Min	Max	Unit
Supply Voltage (V_{CC}) (Note 3)	4.5	5.5	V
Supply Voltage (V_{BB}) (Note 3)	2.2	$V_{CC} - 0.4$	V
DC Input or Output Voltage (V_{IN}, V_{OUT})	0.0	V_{CC}	V
Operation Temperature (T_A)	-40	+85	°C
Electr-Static Discharge Rating TBD		1	kV
Transistor Count			10,300
Typical Values			
θ_{JA} DIP	Board		59°C/W
	Socket		65°C/W
θ_{JA} PLCC	Board		80°C/W
	Socket		88°C/W

DC Electrical Characteristics

$V_{CC} = 5V \pm 10\%$, $V_{BB} = 3V$, $V_{PFAIL} > V_{IH}$, $C_L = 100$ pF (unless otherwise specified)

Symbol	Parameter	Conditions	Min	Max	Units
V_{IH}	High Level Input Voltage (Note 4)	Any Inputs Except OSC IN, OSC IN with External Clock	2.0 $V_{BB} - 0.1$		V V
V_{IL}	Low Level Input Voltage	All Inputs Except OSC IN, OSC IN with External Clock		0.8 0.1	V V
V_{OH}	High Level Output Voltage (Excluding OSC OUT)	$I_{OUT} = -20 \mu A$ $I_{OUT} = -4.0$ mA	$V_{CC} - 0.1$ 3.5		V V
V_{OL}	Low Level Output Voltage (Excluding OSC OUT)	$I_{OUT} = 20 \mu A$ $I_{OUT} = 4.0$ mA		0.1 0.25	V V
I_{IN}	Input Current (Except OSC IN)	$V_{IN} = V_{CC}$ or GND		± 1.0	μA
I_{OZ}	Output TRI-STATE® Current	$V_{OUT} = V_{CC}$ or GND		± 5.0	μA
I_{LKG}	Output High Leakage Current MFO, INTR Pins	$V_{OUT} = V_{CC}$ or GND Outputs Open Drain		± 5.0	μA
I_{CC}	Quiescent Supply Current (Note 7)	$F_{OSC} = 32.768$ kHz $V_{IN} = V_{CC}$ or GND (Note 5) $V_{IN} = V_{CC}$ or GND (Note 6) $V_{IN} = V_{IH}$ or V_{IL} (Note 6)		250 1.0 12.0	μA mA mA
		$F_{OSC} = 4.194304$ MHz or 4.9152 MHz $V_{IN} = V_{CC}$ or GND (Note 6) $V_{IN} = V_{IH}$ or V_{IL} (Note 6)		8 20	mA mA
I_{CC}	Quiescent Supply Current (Single Supply Mode) (Note 7)	$V_{BB} = GND$ $V_{IN} = V_{CC}$ or GND $F_{OSC} = 32.768$ kHz $F_{OSC} = 4.9152$ MHz or 4.194304 MHz		40 7.5	μA mA
I_{BB}	Standby Mode Battery Supply Current (Note 7)	$V_{CC} = GND$ OSC OUT = open circuit, other pins = GND $F_{OSC} = 32.768$ kHz $F_{OSC} = 4.9152$ MHz or 4.194304 MHz		10 400	μA μA
I_{BLK}	Battery Leakage	$2.2V \leq V_{BB} \leq 4.0V$ other pins at GND $V_{CC} = GND, V_{BB} = 4.0V$ $V_{CC} = 5.5V, V_{BB} = 2.2V$	-5	1.5	μA μA

Note 1: Absolute Maximum Ratings are those values beyond which damage to the device may occur.

Note 2: Unless otherwise specified all voltages are referenced to ground.

Note 3: For $F_{OSC} = 4.194304$ or 4.9152 MHz, V_{BB} minimum = 2.8V. In battery backed mode, $V_{BB} \leq V_{CC} - 0.4V$.
Single Supply Mode: Data retention voltage is 2.2V min.
In single Supply Mode (Power connected to V_{CC} pin) $4.5V \leq V_{CC} \leq 5.5V$.

Note 4: This parameter (V_{IH}) is not tested on all pins at the same time.

Note 5: This specification tests I_{CC} with all power fail circuitry disabled, by setting D7 of Interrupt Control Register 1 to 0.

Note 6: This specification tests I_{CC} with all power fail circuitry enabled, by setting D7 of Interrupt Control Register 1 to 1.

Note 7: OSC IN is driven by a signal generator. Contents of the Test Register = 00(H) and the MFO pin is not configured as buffered oscillator out.

8572A

AC Electrical Characteristics

$V_{CC} = 5V \pm 10\%$, $V_{BB} = 3V$, $V_{PFAIL} > V_{IH}$, $C_L = 100 \text{ pF}$ (unless otherwise specified)

Symbol	Parameter	Min	Max	Units
READ TIMING				
t_{AR}	Address Valid Prior to Read Strobe	20		ns
t_{RW}	Read Strobe Width (Note 8)	80		ns
t_{CD}	Chip Select to Data Valid Time		80	ns
t_{RAH}	Address Hold after Read (Note 9)	3		ns
t_{RD}	Read Strobe to Valid Data		70	ns
t_{DZ}	Read or Chip Select to TRI-STATE		60	ns
t_{RCH}	Chip Select Hold after Read Strobe	0		ns
t_{DS}	Minimum Inactive Time between Read or Write Accesses	50		ns
WRITE TIMING				
t_{AW}	Address Valid before Write Strobe	20		ns
t_{WAH}	Address Hold after Write Strobe (Note 9)	3		ns
t_{CW}	Chip Select to End of Write Strobe	90		ns
t_{WW}	Write Strobe Width (Note 10)	80		ns
t_{DW}	Data Valid to End of Write Strobe	50		ns
t_{WDH}	Data Hold after Write Strobe (Note 9)	3		ns
t_{WCH}	Chip Select Hold after Write Strobe	0		ns
INTERRUPT TIMING				
t_{ROLL}	Clock Rollover to \overline{INTR} Out is Typically 16.5 μs			

Note 8: Read Strobe width as used in the read timing table is defined as the period when both chip select and read inputs are low. Hence read commences when both signals are low and terminates when either signal returns high.

Note 9: Hold time is guaranteed by design but not production tested. This limit is not used to calculate outgoing quality levels.

Note 10: Write Strobe width as used in the write timing table is defined as the period when both chip select and write inputs are low. Hence write commences when both signals are low and terminates when either signal returns high.

AC Test Conditions

Input Pulse Levels	GND to 3.0V
Input Rise and Fall Times	6 ns (10%–90%)
Input and Output Reference Levels	1.3V
TRI-STATE Reference Levels (Note 12)	Active High +0.5V Active Low –0.5V

Note 11: $C_L = 100 \text{ pF}$, includes jig and scope capacitance.

Note 12: $S_1 = V_{CC}$ for active low to high impedance measurements.
 $S_1 = \text{GND}$ for active high to high impedance measurements.
 $S_1 = \text{open}$ for all other timing measurements.

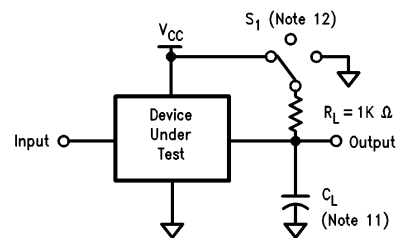

TL/F/9980–2

Capacitance ($T_A = 25^\circ\text{C}$, $f = 1 \text{ MHz}$)

Symbol	Parameter (Note 13)	Typ	Units
C_{IN}	Input Capacitance	5	pF
C_{OUT}	Output Capacitance	7	pF

Note 13: This parameter is not 100% tested.

Note 14: Output rise and fall times 25 ns max (10%–90%) with 100 pF load.

8572AM—Military Version

Absolute Maximum Ratings (Notes 1 & 2)

The 883 specifications are written to reflect the current (at the time of printing) Rel Electrical Test Specifications (RETS) established by National Semiconductor for this product. For a copy of the latest version of the RETS please contact your local National Semiconductor sales office or distributor.

Supply Voltage (V_{CC})	-0.5V to +7.0V
DC Input Voltage (V_{IN})	-0.5V to $V_{CC} + 0.5V$
DC Output Voltage (V_{OUT})	-0.5V to $V_{CC} + 0.5V$
Storage Temperature Range	-65°C to +150°C
Power Dissipation (PD)	500 mW
Lead Temperature (Soldering, 10 sec.)	260°C

DC Electrical Characteristics

$V_{CC} = 5.0V \pm 10\%$, $V_{BB} = 3V$

Operation Conditions

	Min	Max	Unit
Supply Voltage (V_{CC}) (Note 3)	4.5	5.5	V
Supply Voltage (V_{BB}) (Note 3)	2.2	$V_{CC} - 0.4$	V
DC Input or Output Voltage (V_{IN} , V_{OUT})	0.0	V_{CC}	V
Operating Temperature (T_A)	-55	+125	°C
Electro-Static Discharge Rating		1	kV
Typical Values			
θ_{JA} DIP			45°C/W
Board Socket			52°C/W

Symbol	Parameter	V_{CC}	Conditions	Min	Max	Units
V_{IH}	High Level Input Voltage (Note 4)		All Inputs Except OSC IN. OSC IN with External Clock	2.0 $V_{BB} - 0.1$		V V
V_{IL}	Low Level Input Voltage		All Inputs Except OSC IN. OSC IN with External Clock		0.8 0.1	V V
V_{OH}	High Level Output Voltage (Excluding OSC OUT)	5.5V 5.5V	$I_{OUT} = -20 \mu A$ $I_{OUT} = -4.0 mA$	$V_{CC} - 0.1$ 3.5		V V
V_{OL}	Low Level Output Voltage (Excluding OSC OUT)	5.5V 5.5V	$I_{OUT} = 20 \mu A$ $I_{OUT} = 4.0 mA$		0.1 0.25	V V
I_{IN}	Input Current (Except OSC IN)	5.5V	$V_{IN} = V_{CC}$ or GND		± 1.0	μA
I_{OZ}	Output TRI-STATE Current	5.5V	$V_{OUT} = V_{CC}$ or GND		± 5.0	μA
I_{CC}	Quiescent Supply Current (Note 7)	5.5V 5.5V 5.5V 5.5V	$F_{OSC} = 32.768 kHz$ $V_{IN} = V_{CC}$ or GND (Note 5) $V_{IN} = V_{CC}$ or GND (Note 6) $V_{IN} = V_{IH}$ or V_{IL} (Note 6)		275 1.0 12.0	μA mA mA
I_{CC}	Quiescent Supply Current (Single Supply Mode) 5.5V (Note 7)	5.5V	$V_{BB} = GND$, $V_{IN} = V_{CC}$ or GND $F_{OSC} = 32.768 kHz$ $F_{OSC} = 4.9152 MHz$		40 7.5	μA mA
I_{BB}	Standby Mode Battery Supply Current (Note 7)	0V 0V	OSC OUT = Open Circuit, Other Pins = GND $F_{OSC} = 32.768 kHz$ $F_{OSC} = 4.9152 MHz$		10 400	μA μA
I_{BLK}	Battery Leakage	5.5V 5.5V 5.5V	$2.2V \leq V_{BB} \leq 4.0V$ 25°C -55°C +125°C	-5 -5 -5	1.5 3.5 3.5	μA μA μA

Note 1: Absolute Maximum Ratings are those values beyond which damage to the device may occur.

Note 2: Unless otherwise specified all voltages are referenced to ground.

Note 3: For $F_{OSC} = 4.194304$ or $4.9152 MHz$, V_{BB} minimum = 2.8V. In battery backed mode, $V_{BB} \leq V_{CC} - 0.4V$.
Single Supply Mode: Data retention voltage is 2.2V min.
In single Supply Mode (Power connected to V_{CC} pin) $4.5V \leq V_{CC} \leq 5.5V$.

Note 4: This parameter (V_{IH}) is not tested on all pins at the same time.

Note 5: This specification tests I_{CC} with all power fail circuitry disabled, by setting D7 of Interrupt Control Register 1 to 0.

Note 6: This specification tests I_{CC} with all power fail circuitry enabled, by setting D7 of Interrupt Control Register 1 to 1.

Note 7: OSC IN is driven by a signal generator. Contents of the Test Register = 00(H) and the MFO pin is not configured as buffered oscillator out.

8572AM—Military Version

AC Electrical Characteristics

$V_{CC} = 4.5V$ and $5.5V$, $V_{BB} = 3V$, $V_{PFAIL} > V_{IH}$, $C_L = 100$ pF (unless otherwise specified)

Symbol	Parameter	Min	Max	Units
READ TIMING				
t_{AR}	Address Valid Prior to Read Strobe	20		ns
t_{RW}	Read Strobe Width (Note 8)	80		ns
t_{CD}	Chip Select to Data Valid Time		80	ns
t_{RD}	Read Strobe to Valid Data		70	ns
t_{DZ}	Read or Chip Select to TRI-STATE		60	ns
t_{RCH}	Chip Select Hold after Read Strobe	0		ns
t_{DS}	Minimum Inactive Time between Read or Write Accesses	50		ns
WRITE TIMING				
t_{AW}	Address Valid before Write Strobe	20		ns
t_{CW}	Chip Select to End of Write Strobe	90		ns
t_{WW}	Write Strobe Width (Note 9)	80		ns
t_{DW}	Data Valid to End of Write Strobe	50		ns
t_{WCH}	Chip Select Hold after Write Strobe	0		ns

Note 8: Read Strobe width as used in the read timing table is defined as the period when both chip select and read inputs are low. Hence read commences when both signals are low and terminates when either signal returns high.

Note 9: Write Strobe width as used in the write timing table is defined as the period when both chip select and write inputs are low. Hence write commences when both signals are low and terminates when either signal returns high.

AC Test Conditions

Input Pulse Levels	GND to 3.0V
Input Rise and Fall Times	6 ns (10%–90%)
Input and Output Reference Levels	1.3V
TRI-STATE Reference Levels (Note 11)	Active High +0.5V Active Low –0.5V

Note 10: $C_L = 100$ pF, includes jig and scope capacitance.

Note 11: $S_1 = V_{CC}$ for active low to high impedance measurements.
 $S_1 = GND$ for active high to high impedance measurements.
 $S_1 = \text{open}$ for all other timing measurements.

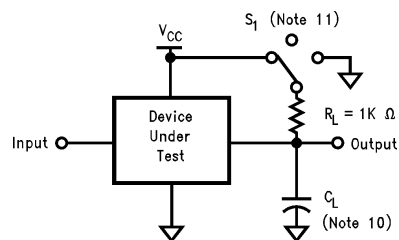

TL/F/9980–24

Capacitance ($T_A = 25^\circ C$, $f = 1$ MHz)

Symbol	Parameter (Note 12)	Typ	Units
C_{IN}	Input Capacitance	5	pF
C_{OUT}	Output Capacitance	7	pF

Note 12: This parameter is not 100% tested.

Note 13: Output rise and fall times 25 ns max (10%–90%) with 100 pF load.

Timing Waveforms

Read Timing Diagram

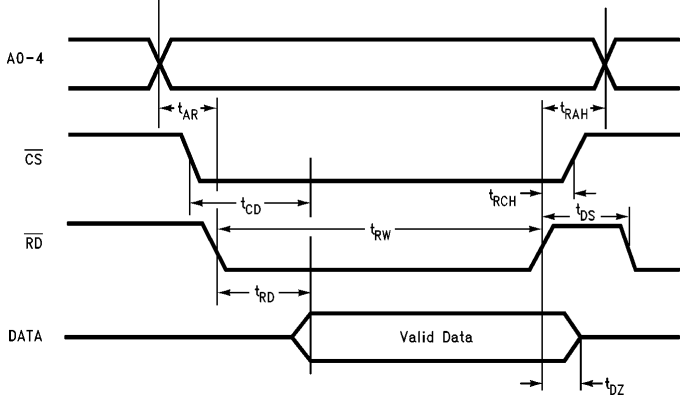

TL/F/9980-3

Write Timing Diagram

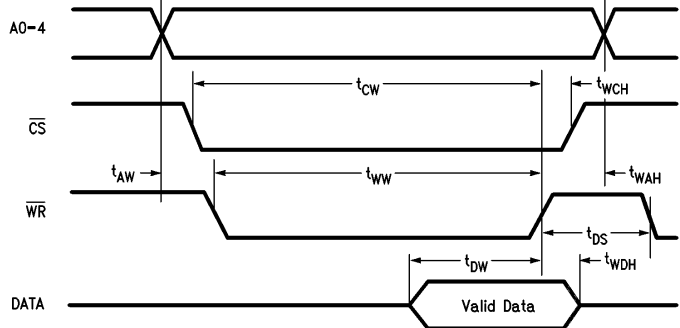

TL/F/9980-4

General Description (Continued)

The DP8572A's interrupt structure provides three basic types of interrupts: Periodic, Alarm/Compare, and Power Fail. Interrupt mask and status registers enable the masking and easy determination of each interrupt.

Pin Description

\overline{CS} , \overline{RD} , \overline{WR} (Inputs): These pins interface to μP control lines. The \overline{CS} pin is an active low enable for the read and write operations. Read and Write pins are also active low and enable reading or writing to the RTC. All three pins are disabled when power failure is detected. However, if a read or write is in progress at this time, it will be allowed to complete its cycle.

A0–A4 (Inputs): These 5 pins are for register selection. They individually control which location is to be accessed. These inputs are disabled when power failure is detected.

OSC IN (Input): OSC OUT (Output): These two pins are used to connect the crystal to the internal parallel resonant oscillator. The oscillator is always running when power is applied to V_{BB} and V_{CC} , and the correct crystal select bits in the Real Time Mode Register have been set.

MFO (Output): The multi-function output can be used as a second interrupt output for interrupting the μP . This pin can also provide an output for the oscillator. The MFO output is configured as push-pull, active high for normal or single power supply operation and as an open drain during stand-by mode ($V_{BB} > V_{CC}$). If in battery backed mode and a pull-up resistor is attached, it should be connected to a voltage no greater than V_{BB} .

\overline{INTR} (Output): The interrupt output is used to interrupt the processor when a timing event or power fail has occurred and the respective interrupt has been enabled. The \overline{INTR} output is permanently configured active low, open drain. If in battery backed mode and a pull-up resistor is attached, it should be connected to a voltage no greater than V_{BB} . The output is a DC voltage level. To clear the \overline{INTR} , write a 1 to the appropriate bit(s) in the Main Status Register.

D0–D7 (Input/Output): These 8 bidirectional pins connect to the host μP 's data bus and are used to read from and write to the RTC. When the \overline{PF} pin goes low and a write is not in progress, these pins are at TRI-STATE.

\overline{PF} (Input): In battery backed mode, this pin can have a digital signal applied to it via some external power detection logic. When $\overline{PF} = \text{logic } 0$ the RTC goes into a lockout mode, in a minimum of 30 μs or a maximum of 63 μs unless lockout delay is programmed. In the single power supply mode, this pin is not useable as an input and should be tied to V_{CC} . Refer to section on Power Fail Functional Description.

V_{BB} (Battery Power Pin): This pin is connected to a back-up power supply. This power supply is switched to the internal circuitry when the V_{CC} becomes lower than V_{BB} . Utilizing this pin eliminates the need for external logic to switch in and out the back-up power supply. If this feature is not to be used then this pin must be tied to ground, the RTC programmed for single power supply only, and power applied to the V_{CC} pin.

V_{CC} : This is the main system power pin.

GND: This is the common ground power pin for both V_{BB} and V_{CC} .

Connection Diagrams

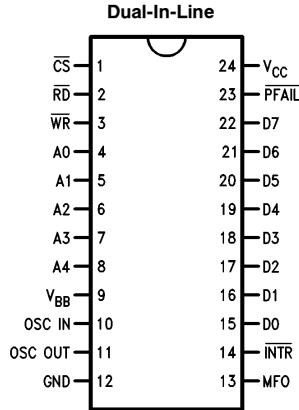

TL/F/9980–5

Top View

Order Number DP8572AN or DP8572AMD/883
See NS Package Number D24C or N24C

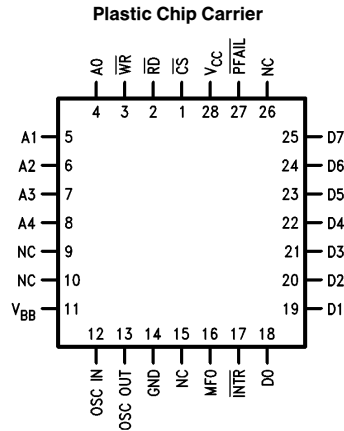

TL/F/9980–6

Top View

Order Number DP8572AV
See NS Package Number V28A

Functional Description

The DP8572A contains a fast access real time clock, interrupt control logic, power fail detect logic, and CMOS RAM. All functions of the RTC are controlled by a set of seven registers. A simplified block diagram that shows the major functional blocks is given in *Figure 1*.

The blocks are described in the following sections:

1. Real Time Clock
2. Oscillator Prescaler
3. Interrupt Logic
4. Power Failure Logic
5. Additional Supply Management

The memory map of the RTC is shown in the memory addressing table. The memory map consists of two 31 byte pages with a main status register that is common to both pages. A control bit in the Main Status Register is used to select either page. *Figure 2* shows the basic concept. Page 0 contains all the clock timer functions, while page 1 has scratch pad RAM. The control registers are split into two separate blocks to allow page 1 to be used entirely as scratch pad RAM. Again a control bit in the Main Status Register is used to select either control register block.

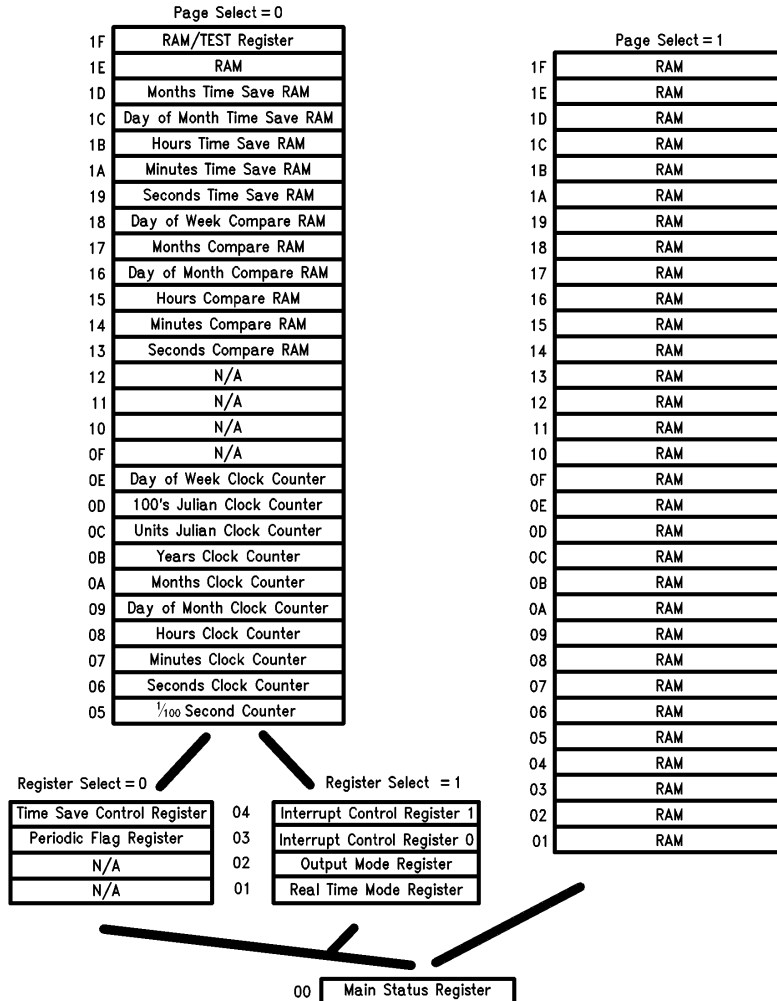

FIGURE 2. DP8572A Internal Memory Map

TL/F/9980-7

Functional Description (Continued)

INITIAL POWER-ON of BOTH V_{BB} and V_{CC}

V_{BB} and V_{CC} may be applied in any sequence. In order for the power fail circuitry to function correctly, whenever power is off, the V_{CC} pin must see a path to ground through a maximum of $1\text{ M}\Omega$. The user should be aware that the control registers will contain random data. The first task to be carried out in an initialization routine is to start the oscillator by writing to the crystal select bits in the Real Time Mode Register. If the DP8572A is configured for single supply mode, an extra $50\ \mu\text{A}$ may be consumed until the crystal select bits are programmed. The user should also ensure that the RTC is not in test mode (see register descriptions).

REAL TIME CLOCK FUNCTIONAL DESCRIPTION

As shown in *Figure 2*, the clock has 10 bytes of counters, which count from $1/100$ of a second to years. Each counter counts in BCD and is synchronously clocked. The count sequence of the individual byte counters within the clock is shown later in Table VII. Note that the day of week, day of month, day of year, and month counters all roll over to 1. The hours counter in 12 hour mode rolls over to 1 and the AM/PM bit toggles when the hours rolls over to 12 (AM = 0, PM = 1). The AM/PM bit is bit D7 in the hours counter.

All other counters roll over to 0. Also note that the day of year counter is 12 bits long and occupies two addresses. Upon initial application of power the counters will contain random information.

READING THE CLOCK: VALIDATED READ

Since clocking of the counter occurs asynchronously to reading of the counter, it is possible to read the counter while it is being incremented (rollover). This may result in an incorrect time reading. Thus to ensure a correct reading of the entire contents of the clock (or that part of interest), it must be read without a clock rollover occurring. In general this can be done by checking a rollover bit. On this chip the periodic interrupt status bits can serve this function. The following program steps can be used to accomplish this.

1. Initialize program for reading clock.
2. Dummy read of periodic status bit to clear it.
3. Read counter bytes and store.
4. Read rollover bit, and test it.
5. If rollover occurred go to 3.
6. If no rollover, done.

To detect the rollover, individual periodic status bits can be polled. The periodic bit chosen should be equal to the highest frequency counter register to be read. That is if only SECONDS through HOURS counters are read, then the SECONDS periodic bit should be used.

READING THE CLOCK: INTERRUPT DRIVEN

Enabling the periodic interrupt mask bits cause interrupts just as the clock rolls over. Enabling the desired update rate and providing an interrupt service routine that executes in less than 10 ms enables clock reading without checking for a rollover.

READING THE CLOCK: LATCHED READ

Another method to read the clock that does not require checking the rollover bit is to write a one into the Time

Save Enable bit (D7) of the Time Save Control Register, and then to write a zero. Writing a one into this bit will enable the clock contents to be duplicated in the Time Save RAM. Changing the bit from a one to a zero will freeze and store the contents of the clock in Time Save RAM. The time then can be read without concern for clock rollover, since internal logic takes care of synchronization of the clock. Because only the bits used by the clock counters will be latched, the Time Save RAM should be cleared prior to use to ensure that random data stored in the unused bits do not confuse the host microprocessor. This bit can also provide time save at power failure, see the Additional Supply Management Functions section. With the Time Save Enable bit at a logical 0, the Time Save RAM may be used as RAM if the latched read function is not necessary.

INITIALIZING AND WRITING TO THE CALENDAR-CLOCK

Upon initial application of power to the RTC or when making time corrections, the time must be written into the clock. To correctly write the time to the counters, the clock would normally be stopped by writing the Start/Stop bit in the Real Time Mode Register to a zero. This stops the clock from counting and disables the carry circuitry. When initializing the clock's Real Time Mode Register, it is recommended that first the various mode bits be written while maintaining the Start/Stop bit reset, and then writing to the register a second time with the Start/Stop bit set.

The above method is useful when the entire clock is being corrected. If one location is being updated the clock need not be stopped since this will reset the prescaler, and time will be lost. An ideal example of this is correcting the hours for daylight savings time. To write to the clock "on the fly" the best method is to wait for the $1/100$ of a second periodic interrupt. Then wait an additional $16\ \mu\text{s}$, and then write the data to the clock.

PRESCALER/OSCILLATOR FUNCTIONAL DESCRIPTION

Feeding the counter chain is a programmable prescaler which divides the crystal oscillator frequency to 32 kHz and further to 100 Hz for the counter chain (see *Figure 3*). The crystal frequency that can be selected are: 32 kHz, 32.768 kHz, 4.9152 MHz, and 4.194304 MHz.

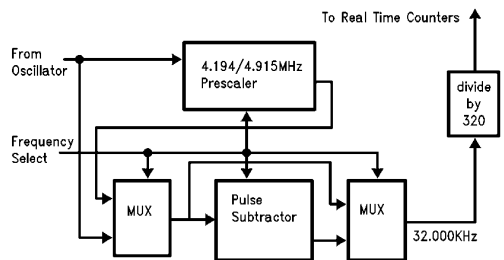

FIGURE 3. Programmable Clock Prescaler Block

TL/F/9980-8

Functional Description (Continued)

The oscillator is programmed via the Real Time Mode Register to operate at various frequencies. The crystal oscillator is designed to offer optimum performance at each frequency. Thus, at 32.768 kHz the oscillator is configured as a low frequency and low power oscillator. At the higher frequencies the oscillator inverter is reconfigured. In addition to the inverter, the oscillator feedback bias resistor is included on chip, as shown in *Figure 4*. The oscillator input may be driven from an external source if desired. Refer to test mode application note for details. The oscillator stability is enhanced through the use of an on chip regulated power supply.

The typical range of trimmer capacitor (as shown in Oscillator Circuit Diagram *Figure 4*, and in the typical application) at the oscillator input pin is suggested only to allow accurate tuning of the oscillator. This range is based on a typical printed circuit board layout and may have to be changed depending on the parasitic capacitance of the printed circuit board or fixture being used. In all cases, the **load capacitance** specified by the crystal manufacturer (nominal value 11 pF for the 32.768 crystal) is what determines proper oscillation. This load capacitance is the series combination of capacitance on each side of the crystal (with respect to ground).

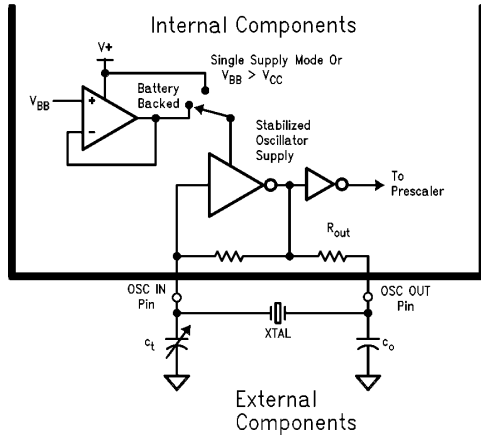

FIGURE 4. Oscillator Circuit Diagram

TL/F/9980-9

XTAL	C _o	C _t	R _{out} (Switched Internally)
32/32.768 kHz	47 pF	2 pF–22 pF	150 kΩ to 350 kΩ
4.194304 MHz	68 pF	0 pF–80 pF	500Ω to 900Ω
4.9152 MHz	68 pF	29 pF–49 pF	500Ω to 900Ω

INTERRUPT LOGIC FUNCTIONAL DESCRIPTION

The RTC has the ability to coordinate processor timing activities. To enhance this, an interrupt structure has been implemented which enables several types of events to cause interrupts. Interrupts are controlled via two Control Registers in block 1 and two Status Registers in block 0. (See Register Description for notes on paging and also *Figure 5* and Table I.)

The interrupts are enabled by writing a one to the appropriate bits in Interrupt Control Register 0 and/or 1.

TABLE I. Registers that are Applicable to Interrupt Control

Register Name	Register Select	Page Select	Address
Main Status Register	X	X	00H
Periodic Flag Register	0	0	03H
Interrupt Control Register 0	1	0	03H
Interrupt Control Register 1	1	0	04H
Output Mode Register	1	0	02H

The Interrupt Status Flag D0, in the Main Status Register, indicates the state of INTR and MFO outputs. It is set when either output becomes active and is cleared when all RTC interrupts have been cleared and no further interrupts are pending (i.e., both INTR and MFO are returned to their inactive state). This flag enables the RTC to be rapidly polled by the μ P to determine the source of an interrupt in a wired-OR interrupt system. (The Interrupt Status Flag provides a true reflection of all conditions routed to the external pins.) Status for the interrupts are provided by the Main Status Register and the Periodic Flag Register. Bits D1–D5 of the Main Status Register are the main interrupt bits.

These register bits will be set when their associated timing events occur. Enabled Alarm comparisons that occur will set its Main Status Register bit to a one. However, an external interrupt will only be generated if the Alarm interrupt enable bit is set (see *Figure 5*).

Disabling the periodic interrupts will mask the Main Status Register periodic bit, but not the Periodic Flag Register bits. The Power Fail Interrupt bit is set when the interrupt is enabled and a power fail event has occurred, and is not reset until the power is restored. If all interrupt enable bits are 0 no interrupt will be asserted. However, status still can be read from the Main Status Register in a polled fashion (see *Figure 5*).

To clear a flag in bits D2 and D3 of the Main Status Register a 1 must be written back into the bit location that is to be cleared. For the Periodic Flag Register reading the status will reset all the periodic flags.

Functional Description (Continued)

Interrupts Fall Into Three Categories:

1. The Alarm Compare Interrupt: Issued when the value in the time compared RAM equals the counter.
2. The Periodic Interrupts: These are issued at every increment of the specific clock counter signal. Thus, an interrupt is issued every minute, second, etc. Each of these interrupts occurs at the roll-over of the specific counter.
3. The Power Fail Interrupt: Issued upon recognition of a power fail condition by the internal sensing logic. The power failed condition is determined by the signal on the PFAIL pin. The internal power fail signal is gated with the chip select signal to ensure that the power fail interrupt does not lock the chip out during a read or write.

ALARM COMPARE INTERRUPT DESCRIPTION

The alarm/time comparison interrupt is a special interrupt similar to an alarm clock wake up buzzer. This interrupt is generated when the clock time is equal to a value programmed into the alarm compare registers. Up to six bytes can be enabled to perform alarm time comparisons on the counter chain. These six bytes, or some subset thereof, would be loaded with the future time at which the interrupt will occur. Next, the appropriate bits in the Interrupt Control Register 1 are enabled or disabled (refer to detailed description of Interrupt Control Register 1). The RTC then compares these bytes with the clock time. When all the enabled compare registers equal the clock time an alarm interrupt is issued, but only if the alarm compare interrupt is enabled can the interrupt be generated externally. Each alarm compare bit in the Control Register will enable a specific byte for comparison to the clock. Disabling a compare byte is the same as setting its associated counter comparator to an "always equal" state. For example, to generate an interrupt at 3:15 AM of every day, load the hours compare with 03 (BCD), the minutes compare with 15 (BCD) and the faster counters with 00 (BCD), and then disable all other compare registers. So every day when the time rolls over from 3:14:59.99, an interrupt is issued. This bit may be reset by writing a one to bit D3 in the Main Status Register at any time after the alarm has been generated.

If time comparison for an individual byte counter is disabled, that corresponding RAM location can then be used as general purpose storage.

PERIODIC INTERRUPTS DESCRIPTION

The Periodic Flag Register contains six flags which are set by real-time generated "ticks" at various time intervals, see

Figure 5. These flags constantly sense the periodic signals and may be used whether or not interrupts are enabled. These flags are cleared by any read or write operation performed on this register.

To generate periodic interrupts at the desired rate, the associated Periodic Interrupt Enable bit in Interrupt Control Register 0 must be set. Any combination of periodic interrupts may be enabled to operate simultaneously. Enabled periodic interrupts will now affect the Periodic Interrupt Flag in the Main Status Register.

When a periodic event occurs, the Periodic Interrupt Flag in the Main Status Register is set, causing an interrupt to be generated. The μP clears both flag and interrupt by writing a "1" to the Periodic Interrupt Flag. The individual flags in the periodic Interrupt Flag Register do not require clearing to cancel the interrupt.

If all periodic interrupts are disabled and a periodic interrupt is left pending (i.e., the Periodic Interrupt Flag is still set), the Periodic Interrupt Flag will still be required to be cleared to cancel the pending interrupt.

POWER FAIL INTERRUPTS DESCRIPTION

The Power Fail Status Flag in the Main Status Register monitors the state of the internal power fail signal. This flag may be interrogated by the μP , but it cannot be cleared; it is cleared automatically by the RTC when system power is restored. To generate an interrupt when the power fails, the Power Fail Interrupt Enable bit in Interrupt Control Register 1 is set. Although this interrupt may not be cleared, it may be masked by clearing the Power Fail Interrupt Enable bit.

POWER FAILURE CIRCUITRY FUNCTIONAL DESCRIPTION

Since the clock must be operated from a battery when the main system supply has been turned off, the DP8572A provides circuitry to simplify design in battery backed systems. This switches over to the back up supply, and isolates itself from the host system. *Figure 6* shows a simplified block diagram of this circuitry, which consists of three major sections; 1) power loss logic; 2) battery switch over logic; and 3) isolation logic.

Detection of power loss occurs when $\overline{\text{PFAIL}}$ is low. Debounce logic provides a 30 μs –63 μs debounce time, which will prevent noise on the PFAIL pin from being interpreted as a system failure. After 30 μs –63 μs the debounce logic times out and a signal is generated indicating that system power is marginal and is failing. The Power Fail Interrupt will then be generated.

Functional Description (Continued)

TL/F/9980-10

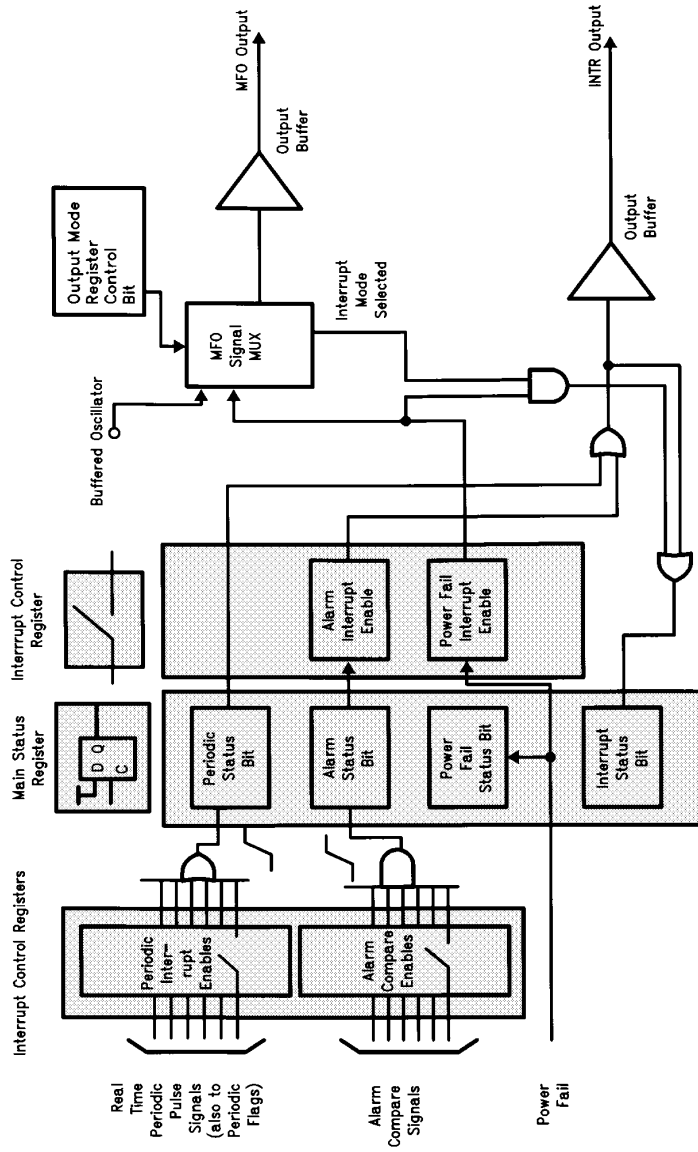
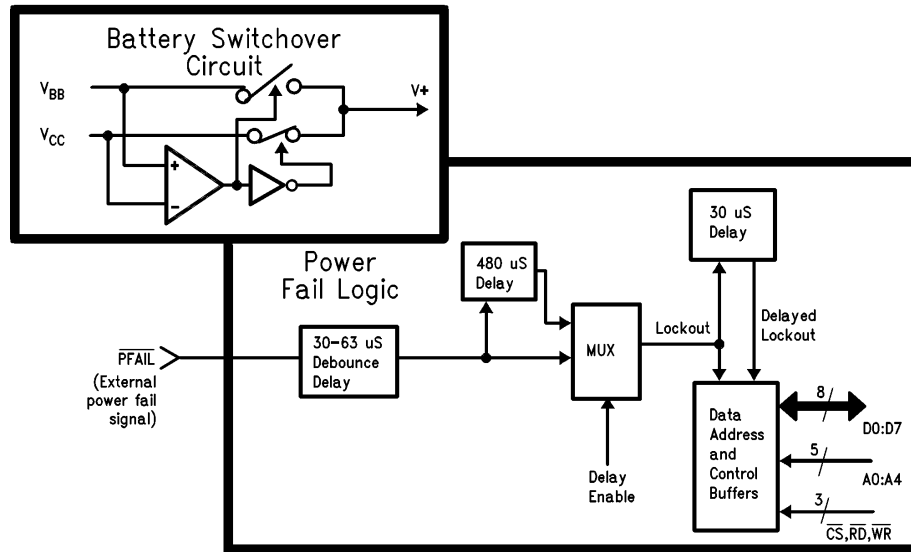

FIGURE 5. Interrupt Control Logic Overview

Functional Description (Continued)



TL/F/9980-11

FIGURE 6. System-Battery Switchover (Upper Left), Power Fail and Lock-Out Circuits (Lower Right)

If chip select is low when a power failure is detected, a safety circuit will ensure that if a read or write is held active continuously for greater than 30 μ s after the power fail signal is asserted, the lock-out will be forced. If a lock-out delay is enabled, the DP8572A will remain active for 480 μ s after power fail is detected. This will enable the μ P to perform last minute bookkeeping before total system collapse. When the host CPU is finished accessing the RTC it may force the bus lock-out before 480 μ s has elapsed by resetting the delay enable bit.

The battery switch over circuitry is completely independent of the PFAIL pin. A separate circuit compares V_{CC} to the V_{BB} voltage. As the main supply fails, the RTC will continue to operate from the V_{CC} pin until V_{CC} falls below the V_{BB} voltage. At this time, the battery supply is switched in, V_{CC} is disconnected, and the device is now in the standby mode. If indeterminate operation of the battery switch over circuit is to be avoided, then the voltage at the V_{CC} pin must not be allowed to equal the voltage at the V_{BB} pin.

After the generation of a lock-out signal, and eventual switch in of the battery supply, the pins of the RTC will be configured as shown in Table II. Outputs that have a pull-up

resistor should be connected to a voltage no greater than V_{BB} .

TABLE II. Pin Isolation during a Power Failure

Pin	$\overline{\text{PFAIL}} = \text{Logic 0}$	Standby Mode $V_{BB} > V_{CC}$
$\overline{\text{CS}}, \overline{\text{RD}}, \overline{\text{WR}}$	Locked Out	Locked Out
A0-A4	Locked Out	Locked Out
D0-D7	Locked Out	Locked Out
Oscillator	Not Isolated	Not Isolated
$\overline{\text{PFAIL}}$	Not Isolated	Not Isolated
INTR, MFO	Not Isolated	Open Drain

The Interrupt Power Fail Operation bit in the Real-Time Mode Register determine whether or not the interrupts will continue to function after a power fail event.

As power returns to the system, the battery switch over circuit will switch back to V_{CC} power as soon as it becomes greater than the battery voltage. The chip will remain in the locked out state as long as $\overline{\text{PFAIL}} = 0$. When $\overline{\text{PFAIL}} = 1$

Functional Description (Continued)

the chip is unlocked, but only after another 30 μs min \rightarrow 63 μs max debounce time. The system designer must ensure that his system is stable when power has returned.

The power fail circuitry contains active linear circuitry that draws supply current from V_{CC} . In some cases this may be undesirable, so this circuit can be disabled by masking the power fail interrupt. The power fail input can perform all lock-out functions previously mentioned, except that no external interrupt will be issued. Note that the linear power fail circuitry is switched off automatically when using V_{BB} in standby mode.

LOW BATTERY, INITIAL POWER ON DETECT, AND POWER FAIL TIME SAVE

There are three other functions provided on the DP8572A to ease power supply control. These are an initial Power On detect circuit, which also can be used as a time keeping failure detect, a low battery detect circuit, and a time save on power failure.

On initial power up the Oscillator Fail Flag will be set to a one and the real time clock start bit reset to a zero. This indicates that an oscillator fail event has occurred, and time keeping has failed.

The Oscillator Fail flag will not be reset until the real-time clock is started. This allows the system to discriminate between an initial power-up and recovery from a power failure. If the battery backed mode is selected, then bit D6 of the Periodic Flag Register must be written low. This will not affect the contents of the Oscillator Fail Flag.

Another status bit is the low battery detect. This bit is set only when the clock is operating under the V_{CC} pin, and when the battery voltage is determined to be less than 2.1V (typical). When the power fail interrupt enable bit is low, it disables the power fail circuit and will also shut off the low battery voltage detection circuit as well.

To relieve CPU overhead for saving time upon power failure, the Time Save Enable bit is provided to do this automatically. (See also Reading the Clock: Latched Read.) The Time Save Enable bit, when set, causes the Time Save RAM to follow the contents of the clock. This bit can be reset by software, but if set before a power failure occurs, it will automatically be reset when the clock switches to the battery supply (not when a power failure is detected by the $\overline{\text{PFAIL}}$ pin). Thus, writing a one to the Time Save bit enables both a software write or power fail write.

SINGLE POWER SUPPLY APPLICATIONS

The DP8572A can be used in a single power supply application. To achieve this, the V_{BB} pin must be connected to ground, and the power connected to V_{CC} and $\overline{\text{PFAIL}}$ pins. The Oscillator Failed/Single Supply bit in the Periodic Flag Register should be set to a logic 1, which will disable the oscillator battery reference circuit. The power fail interrupt should also be disabled. This will turn off the linear power fail detection circuits, and will eliminate any quiescent power drawn through these circuits. Until the crystal select bits are initialized, the DP8572A may consume about 50 μA due to arbitrary oscillator selection at power on.

(This extra 50 μA is not consumed if the battery backed mode is selected).

DETAILED REGISTER DESCRIPTION

There are 5 external address bits: Thus, the host microprocessor has access to 28 locations at one time. An internal switching scheme provides a total of 61 locations.

This complete address space is organized into two pages. Page 0 contains two blocks of control registers, timers, real time clock counters, and special purpose RAM, while page 1 contains general purpose RAM. Using two blocks enables the 9 control registers to be mapped into 5 locations. The only register that does not get switched is the Main Status Register. It contains the page select bit and the register select bit as well as status information.

A memory map is shown in *Figure 2* and register addressing in Table III. They show the name, address and page locations for the DP8572A.

TABLE III. Register/Counter/RAM Addressing for DP8572A

A0-4	PS (Note 1)	RS (Note 2)	Description
CONTROL REGISTERS			
00	X	X	Main Status Register
03	0	0	Periodic Flag Register
04	0	0	Time Save Control Register
01	0	1	Real Time Mode Register
02	0	1	Output Mode Register
03	0	1	Interrupt Control Register 0
04	0	1	Interrupt Control Register 1
COUNTERS (CLOCK CALENDAR)			
05	0	X	1/100, 1/10 Seconds (0-99)
06	0	X	Seconds (0-59)
07	0	X	Minutes (0-59)
08	0	X	Hours (1-12, 0-23)
09	0	X	Days of Month (1-28/29/30/31)
0A	0	X	Months (1-12)
0B	0	X	Years (0-99)
0C	0	X	Julian Date (LSB) (0-99) (Note 3)
0D	0	X	Julian Date (0-3)
0E	0	X	Day of Week (1-7)
TIME COMPARE RAM			
13	0	X	Sec Compare RAM (0-59)
14	0	X	Min Compare RAM (0-59)
15	0	X	Hours Compare RAM (1-12, 0-23)
16	0	X	DOM Compare RAM (1-28/29/30/31)
17	0	X	Months Compare RAM (1-12)
18	0	X	DOW Compare RAM (1-7)
TIME SAVE RAM			
19	0	X	Seconds Time Save RAM
1A	0	X	Minutes Time Save RAM
1B	0	X	Hours Time Save RAM
1C	0	X	Day of Month Time Save RAM
1D	0	X	Months Time Save RAM
1E	0	1	RAM
1F	0	X	RAM/Test Mode Register
01-1F	1	X	2nd Page General Purpose RAM

Note 1: PS—Page Select (Bit D7 of Main Status Register)

Note 2: RS—Register Select (Bit D6 of Main Status Register)

Note 3: The LSB counters count 0 \rightarrow 99 until the hundreds of days counter reaches 3. Then the LSB counters count to 65 or 66 (if a leap year). The rollover is from 365/366 to 1.

Functional Description (Continued)

MAIN STATUS REGISTER

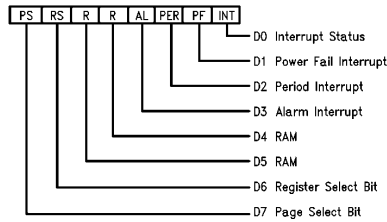

TL/F/9980-12

The Main Status Register is always located at address 0 regardless of the register block or the page selected.

D0: This read only bit is a general interrupt status bit that is taken directly from the interrupt pins. The bit is a one when an interrupt is pending on either the INTR pin or the MFO pin (when configured as an interrupt). This is unlike D3 which can be set by an internal event but may not cause an interrupt. This bit is reset when the interrupt status bits in the Main Status Register are cleared.

D1–D3: These three bits of the Main Status Register are the main interrupt status bits. Any bit may be a one when any of the interrupts are pending. Once an interrupt is asserted the μ P will read this register to determine the cause. These interrupt status bits are not reset when read. Except for D1, to reset an interrupt a one is written back to the corresponding bit that is being tested. D1 is reset whenever the PFAIL pin = logic 1. This prevents loss of interrupt status when reading the register in a polled mode. D1 and D3 are set regardless of whether these interrupts are masked or not by bits D6 and D7 of Interrupt Control Registers 0 and 1.

D4–D5: General purpose RAM bits.

D6 and D7: These bits are Read/Write bits that control which register block or RAM page is to be selected. Bit D6 controls the register block to be accessed (see memory map). The memory map of the clock is further divided into two memory pages. One page is the registers, clock and timers, and the second page contains 31 bytes of general purpose RAM. The page selection is determined by bit D7.

PERIODIC FLAG REGISTER

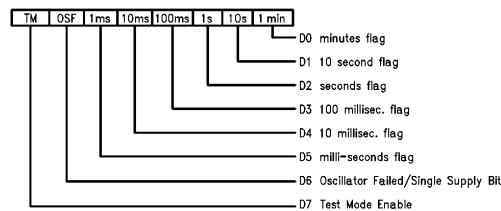

TL/F/9980-13

The Periodic Flag Register has the same bit for bit correspondence as Interrupt Control Register 0 except for D6 and D7. For normal operation (i.e., not a single supply application) this register must be written to on initial power up or after an oscillator fail event. D0–D5 are read only bits, D6 and D7 are read/write.

D0–D5: These bits are set by the real time rollover events: (Time Change = 1). The bits are reset when the register is read and can be used as selective data change flags.

D6: This bit performs a dual function. When this bit is read, a one indicates that an oscillator failure has occurred and the time information may have been lost. Some of the ways an oscillator failure might be caused are: failure of the crystal, shorting OSC IN or OSC OUT to GND or V_{CC} , removal of crystal, removal of battery when in the battery backed mode (when a "0" is written to D6), lowering the voltage at the V_{BB} pin to a value less than 2.2V when in the battery backed mode. Bit D6 is automatically set to 1 on initial power-up or an oscillator fail event. The oscillator fail flag is reset by writing a one to the clock start/stop bit in the Real Time Mode Register, with the crystal oscillating.

When D6 is written to, it defines whether the TCP is being used in battery backed (normal) or in a single supply mode application. When set to a one this bit configures the TCP for single power supply applications. This bit is automatically set on initial power-up or an oscillator fail event. When set, D6 disables the oscillator reference circuit. The result is that the oscillator is referenced to V_{CC} . When a zero is written to D6 the oscillator reference is enabled, thus the oscillator is referenced to V_{BB} . This allows operation in standard battery standby applications.

At initial power on, if the DP8572A is going to be programmed for battery backed mode, the V_{BB} pin should be connected to a potential in the range of 2.2V to $V_{CC} - 0.4V$.

For single supply mode operation, the V_{BB} pin should be connected to GND and the PFAIL pin connected to V_{CC} .

D7: Writing a one to this bit enables the test mode register at location 1F (see Table III). This bit should be forced to zero during initialization for normal operation. If the test mode has been entered, clear the test mode register before leaving test mode. (See separate test mode application note for further details.)

TIME SAVE CONTROL REGISTER

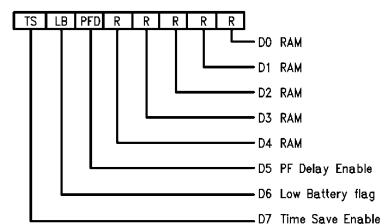

TL/F/9980-14

D0–D4: General purpose RAM bits.

Functional Description (Continued)

D5: The Delay Enable bit is used when a power fail occurs. If this bit is set, a 480 μ s delay is generated internally before the μ P interface is locked out. This will enable the μ P to access the registers for up to 480 μ s after it receives a power fail interrupt. After a power failure is detected but prior to the 480 μ s delay timing out, the host μ P may force immediate lock out by resetting the Delay Enable bit. Note if this bit is a 0 when power fails then after a delay of 30 μ s min/63 μ s max the μ P cannot read the chip.

D6: This read only bit is set and reset by the voltage at the V_{BB} pin. It can be used by the μ P to determine whether the battery voltage at the V_{BB} pin is getting too low. A comparator monitors the battery and when the voltage is lower than 2.1V (typical) this bit is set. The power fail interrupt must be enabled to check for a low battery voltage.

D7: Time Save Enable bit controls the loading of real-time-clock data into the Time Save RAM. When a one is written to this bit the Time Save RAM will follow the corresponding clock registers, and when a zero is written to this bit the time in the Time Save RAM is frozen. This eliminates any synchronization problems when reading the clock, thus negating the need to check for a counter rollover during a read cycle.

This bit must be set to a one prior to power failing to enable the Time Save feature. When the power fails this bit is automatically reset and the time is saved in the Time Save RAM.

REAL TIME MODE REGISTER

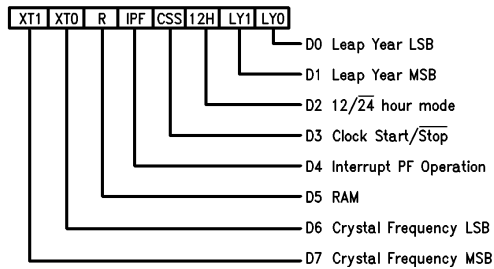

TL/F/9980-15

D0-D1: These are the leap year counter bits. These bits are written to set the number of years from the previous leap year. The leap year counter increments on December 31st and it internally enables the February 29th counter state. This method of setting the leap year allows leap year to occur whenever the user wishes to, thus providing flexibility in implementing Japanese leap year function.

LY1	LY0	Leap Year Counter
0	0	Leap Year Current Year
0	1	Leap Year Last Year
1	0	Leap Year 2 Years Ago
1	1	Leap Year 3 Years Ago

D2: The count mode for the hours counter can be set to either 24 hour mode or 12 hour mode with AM/PM indicator. A one will place the clock in 12 hour mode.

D3: This bit is the master Start/Stop bit for the clock. When a one is written to this bit the real time counter's prescaler and counter chain are enabled. When this bit is reset to zero the contents of the real time counter is stopped and the prescaler is cleared. When the RTC is initially powered up this bit will be held at a logic 0 until the oscillator starts functioning correctly after which this bit may be modified. If an oscillator fail event occurs, this bit will be reset to logic 0.

D4: This bit controls the operation of the interrupt output in standby mode. If set to a one it allows Alarm, Periodic, and Power Fail interrupts to be functional in standby mode. Note that the MFO pin is configured as open drain in standby mode.

If bit D4 is set to a zero then bits D0-D5 of Interrupt Control Register 0 and bits D6 and D7 of Interrupt Control Register 1 will be reset when the RTC enters the standby mode ($V_{BB} > V_{CC}$). They will have to be re-configured when system (V_{CC}) power is restored.

D5: General purpose RAM.

D6 and D7: These two bits select the crystal clock frequency as per the following table:

XT1	XT0	Crystal Frequency
0	0	32.768 kHz
0	1	4.194304 MHz
1	0	4.9152 MHz
1	1	32.000 kHz

All bits are Read/Write, and any mode written into this register can be determined by reading the register. On initial power up these bits are random.

OUTPUT MODE REGISTER

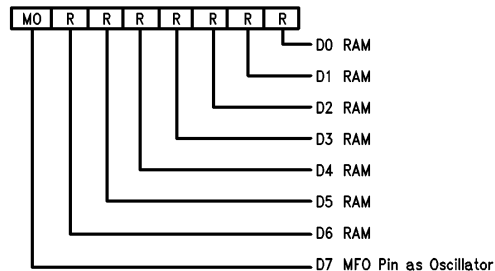

TL/F/9980-16

D0-D6: General Purpose RAM

Functional Description (Continued)

D7: This bit is used to program the signal appearing at the MFO output, as follows:

D7	MFO Output Signal
0	Power Fail Interrupt
1	Buffered Crystal Oscillator

INTERRUPT CONTROL REGISTER 0

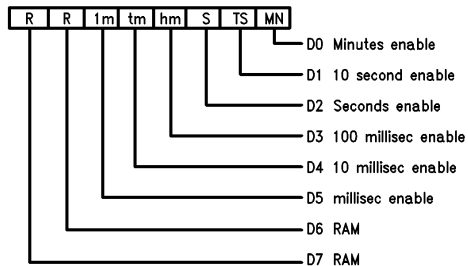

TL/F/9980-17

D0–D5: These bits are used to enable one of the selected periodic interrupts by writing a one into the appropriate bit. These interrupts are issued at the rollover of the clock. For example, the minutes interrupt will be issued whenever the minutes counter increments. In all likelihood the interrupt will be enabled asynchronously with the real time change. Therefore, the very first interrupt will occur in less than the periodic time chosen, but after the first interrupt all subsequent interrupts will be spaced correctly. These interrupts are useful when minute, second, real time reading, or task switching is required. When all six bits are written to a 0 this disables periodic interrupts from the Main Status Register and the interrupt pin. If a battery backed mode is selected and the DP8572A is in standby ($V_{BB} > V_{CC}$), then these bits are controlled by D4 of the Real Time Mode Register.

D6 and D7: General Purpose RAM.

INTERRUPT CONTROL REGISTER 1

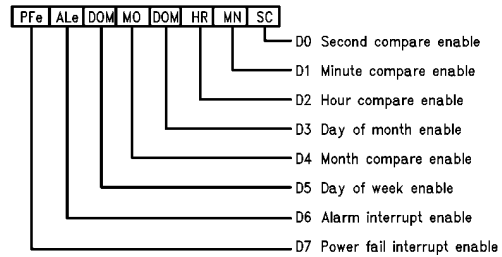

TL/F/9980-18

D0–D5: Each of these bits are enable bits which will enable a comparison between an individual clock counter and its associated compare RAM. If any bit is a zero then that clock-RAM comparator is set to the “always equal” state and the associated TIME COMPARE RAM byte can be used as general purpose RAM. However, to ensure that an alarm interrupt is not generated at bit D3 of the Main Status Register, all bits must be written to a logic zero.

D6: In order to generate an external alarm compare interrupt to the μ P from bit D3 of the Main Status Register, this bit must be written to a logic 1. If a battery backed mode is selected and the DP8572A is in standby ($V_{BB} > V_{CC}$), then this bit is controlled by D4 of the Real Time Mode Register.

D7: The MSB of this register is the enable bit for the Power Fail Interrupt. When this bit is set to a one an interrupt will be generated to the μ P when $V_{BB} > V_{CC}$. If a battery backed mode is selected and the DP8572A is in standby ($V_{BB} > V_{CC}$), then this bit is controlled by D4 of the Real Time Mode Register.

This bit also enables the low battery detection analog circuitry.

Control and Status Register Address Bit Map

D7	D6	D5	D4	D3	D2	D1	D0	
Main Status Register PS = X RS = X ADDRESS = 00H								
R/W	R/W	R/W	R/W	R/W ¹	R/W ¹	R ²	R ³	
Page Select	Register Select	RAM	RAM	Alarm Interrupt	Periodic Interrupt	Power Fail Interrupt	Interrupt Status	1. Reset by writing 1 to bit.
Periodic Flag Register PS = 0 RS = 0 Address = 03H								2. Set/reset by voltage at PFAIL pin.
R/W	R/W ⁴	R ⁵	R ⁵	R ⁵	R ⁵	R ⁵	R ⁵	3. Reset when all pending interrupts are removed.
Test Mode	Osc. Fail/Single Supply	1 ms Flag	10 ms Flag	100 ms Flag	Seconds Flag	10 Second Flag	Minute Flag	4. Read Osc fail Write 0 Batt-Backed Mode Write 1 Single Supply Mode
Time Save Control Register PS = 0 RS = 0 Address = 04H								5. Reset by positive edge of read.
R/W	R ⁶	R/W	R/W	R/W	R/W	R/W	R/W	
Time Save Enable	Low Battery Flag	Power Fail Delay Enable	RAM	RAM	RAM	RAM	RAM	6. Set and reset by V _{BB} voltage.
Real Time Mode Register PS = 0 RS = 1 Address = 01H								
Crystal Freq. XT1	Crystal Freq. XT0	RAM	Interrupt EN on Back-Up	Clock Start/Stop	12/24 Hr. Mode	Leap Year MSB	Leap Year LSB	All Bits R/W
Output Mode Register PS = 0 RS = 1 Address = 02H								
MFO as Crystal	RAM	RAM	RAM	RAM	RAM	RAM	RAM	All Bits R/W
Interrupt Control Register 0 PS = 0 RS = 1 Address = 03H								
RAM	RAM	1 ms Interrupt Enable	10 ms Interrupt Enable	100 ms Interrupt Enable	Seconds Interrupt Enable	10 Second Interrupt Enable	Minute Interrupt Enable	All Bits R/W
Interrupt Control Register 1 PS = 0 RS = 1 Address = 04H								
Power Fail Interrupt Enable	Alarm Interrupt Enable	DOW Interrupt Enable	Month Interrupt Enable	DOM Interrupt Enable	Hours Interrupt Enable	Minute Interrupt Enable	Second Interrupt Enable	All Bits R/W

Application Hints

Suggested Initialization Procedure for DP8572A in Battery Backed Applications that use the V_{BB} Pin.

1. Enter the test mode by writing a 1 to bit D7 in the Periodic Flag Register.
2. Write zero to the RAM/TEST mode Register located in page 0, address HEX 1F.
3. Leave the test mode by writing a 0 to bit D7 in the Periodic Flag Register. Steps 1,2,3 guarantee that if the test mode had been entered during power on (due to random pulses from the system), all test mode conditions are cleared. Most important is that the OSC Fail Disable bit is cleared. Refer to AN-589 for more information on test mode operation.
4. After power on (V_{CC} and V_{BB} powered), select the correct crystal frequency bits (D7, D6 in the Real Time Mode Register) as shown in Table IV.

TABLE IV

Frequency	D7	D6
32.768 KHz	0	0
4.194304 MHz	0	1
4.9152 MHz	1	0
32.0 KHz	1	1

5. Enter a software loop that does the following:
 - Set a 3 second(approx) software counter. The crystal oscillator may take 1 second to start.
- 5.1 Write a 1 to bit D3 in the Real Time Mode Register (try to start the clock). Make sure the crystal select bits remain the same as in step 1. Under normal operation, this bit can be set only if the oscillator is running. During the software loop, RAM, real time counters, output configuration, interrupt control and timer functions may be initialized.
6. Test bit D6 in the Periodic Flag Register:
 - IF a 1**, go to 5.1. If this bit remains a 1 after 3 seconds, then abort and check hardware. The crystal may be defective or not installed. There may be a short at OSC IN or OSC OUT to V_{CC} or GND, or to some impedance that is less than 10 MΩ.
 - IF a 0**, then the oscillator is running, go to step 7.
7. Write a 0 to bit D6 in the Periodic Flag Register. This action puts the clock chip in the battery backed mode. This mode can be entered only if the OSC fail flag (bit D6 of the Periodic Flag Register) is a 0. Reminder, Bit D6 is a dual function bit. When read, D6 returns oscillator status. When written, D6 causes either the Battery Backed Mode, or the Single Supply Mode of operation. The only method to ensure the chip is in the battery backed mode is to measure the waveform at the OSC OUT pin. If the battery backed mode was selected successfully, then the peak to peak waveform at OSC OUT is referenced to the battery voltage. If not in battery backed mode, the waveform is referenced to V_{CC}. The measurement should be made with a high impedance low capacitance probe (10 MΩ, 10 pF oscilloscope probe or better). Typical peak to peak swings are within 0.6V of V_{CC} and ground respectively.
8. Write a 1 to bit D7 of Interrupt Control Register 1. This action enables the PFAIL pin and associated circuitry.
9. Write a 1 to bit D4 of the Real Time Mode Register. This action ensures that bit D7 of Interrupt Control Register 1 remains a 1 when V_{BB} > V_{CC} (Standby Mode).
10. Initialize the rest of the chip as needed.

Typical Application

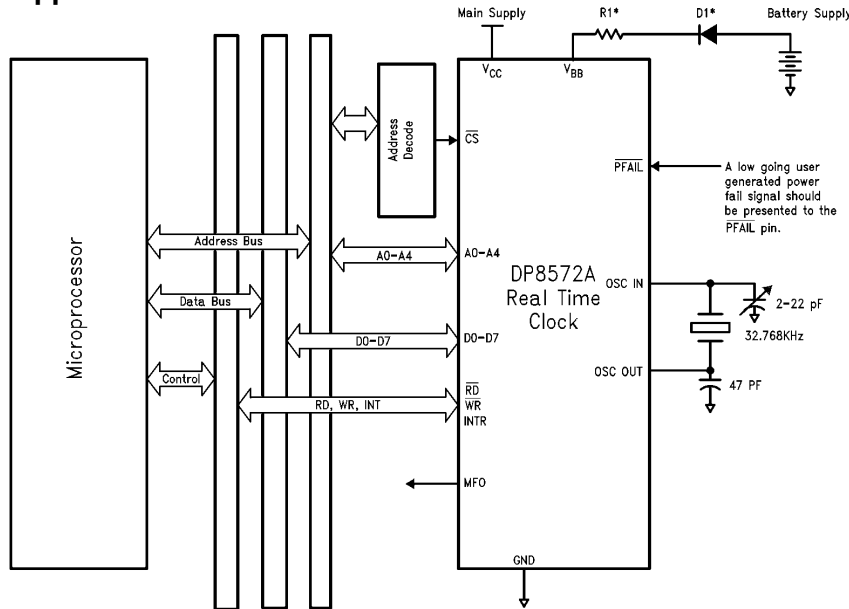

*These components may be necessary to meet UL requirements for lithium batteries. Consult battery manufacturer.

TL/F/9980-19

Typical Performance Characteristics

**Operating Current vs Supply Voltage
(Single Supply Mode)
F_{OSC} = 32.768 kHz**

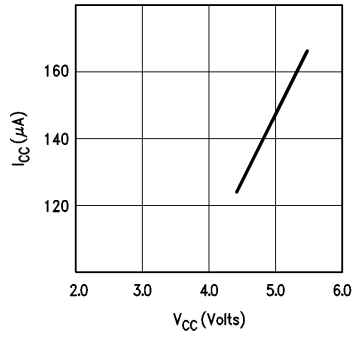

TL/F/9980-20

**Operating Current vs Supply Voltage
(Battery Backed Mode)
F_{OSC} = 32.768 kHz**

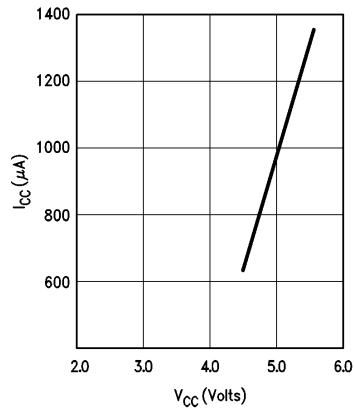

TL/F/9980-21

**Standby Current vs Power Supply Voltage
(F_{OSC} = 32.768 kHz)**

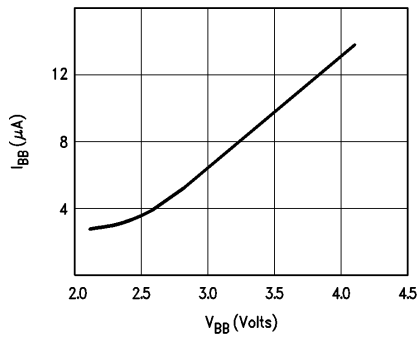

TL/F/9980-22

**Standby Current vs Power Supply Voltage
(F_{OSC} = 4.194304 MHz)**

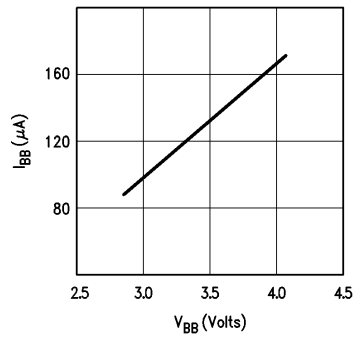

TL/F/9980-23

Physical Dimensions inches (millimeters)

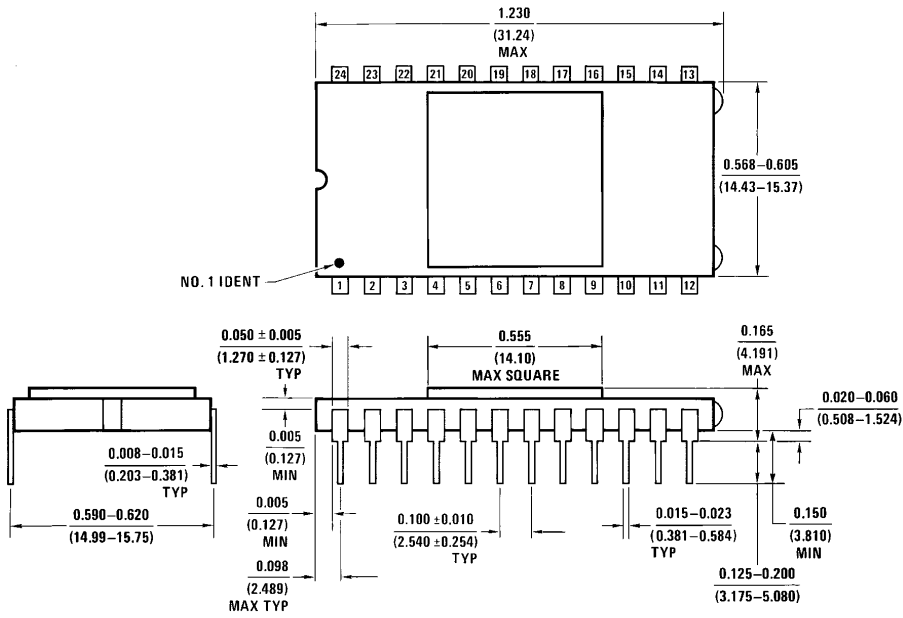

D24C (REV G)

24-Lead Hermetically Sealed Dual-In-Line Package (D)
Order Number DP8572AMD/883
NS Package Number D24C

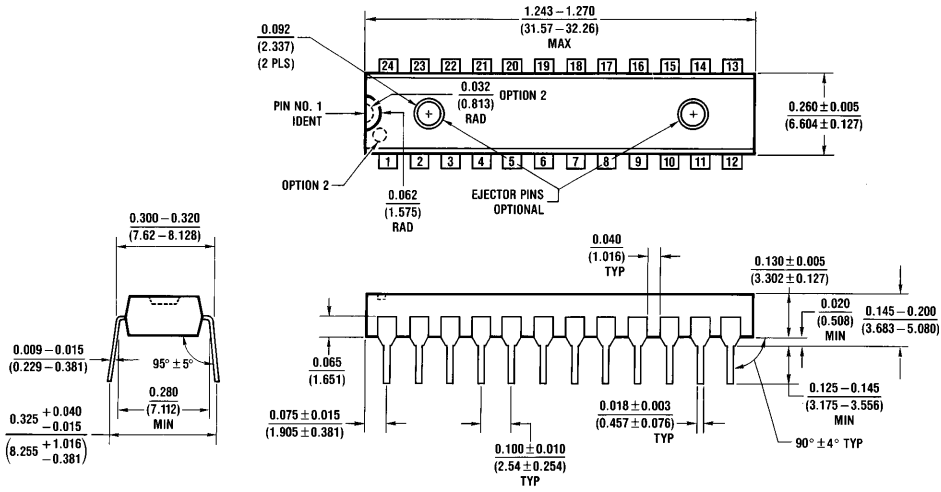

N24C (REV F)

Molded Dual-In-Line Package (N)
Order Number DP8572AN
NS Package Number N24C

Physical Dimensions inches (millimeters) (Continued)

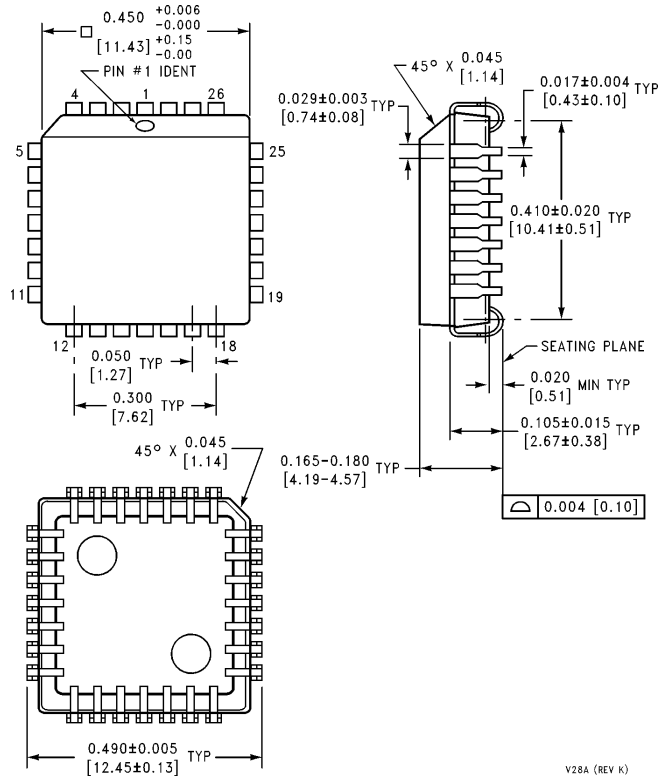

Plastic Chip Carrier Package (V)
Order Number DP8572AV
NS Package Number V28A

V28A (REV K)

LIFE SUPPORT POLICY

NATIONAL'S PRODUCTS ARE NOT AUTHORIZED FOR USE AS CRITICAL COMPONENTS IN LIFE SUPPORT DEVICES OR SYSTEMS WITHOUT THE EXPRESS WRITTEN APPROVAL OF THE PRESIDENT OF NATIONAL SEMICONDUCTOR CORPORATION. As used herein:

1. Life support devices or systems are devices or systems which, (a) are intended for surgical implant into the body, or (b) support or sustain life, and whose failure to perform, when properly used in accordance with instructions for use provided in the labeling, can be reasonably expected to result in a significant injury to the user.
2. A critical component is any component of a life support device or system whose failure to perform can be reasonably expected to cause the failure of the life support device or system, or to affect its safety or effectiveness.



National Semiconductor Corporation
 2900 Semiconductor Drive
 P.O. Box 58090
 Santa Clara, CA 95052-8090
 Tel: (800) 272-9959
 TWX: (910) 339-9240

National Semiconductor GmbH
 Livny-Gargan-Str. 10
 D-82256 Fürstenfeldbruck
 Germany
 Tel: (81-41) 35-0
 Telex: 527849
 Fax: (81-41) 35-1

National Semiconductor Japan Ltd.
 Sumitomo Chemical Engineering Center
 Bldg. 7F
 1-7-1, Nakase, Mihama-Ku
 Chiba-City,
 Chiba Prefecture 261
 Tel: (043) 299-2300
 Fax: (043) 299-2500

National Semiconductor Hong Kong Ltd.
 13th Floor, Straight Block,
 Ocean Centre, 5 Canton Rd.
 Tsimshatsui, Kowloon
 Hong Kong
 Tel: (852) 2737-1600
 Fax: (852) 2736-9960

National Semicondutores Do Brazil Ltda.
 Rue Deputado Lacorda Franco
 120-3A
 Sao Paulo-SP
 Brazil 05418-000
 Tel: (55-11) 212-5066
 Telex: 391-1131931 NSBR BR
 Fax: (55-11) 212-1181

National Semiconductor (Australia) Pty. Ltd.
 Building 16
 Business Park Drive
 Monash Business Park
 Nottinghill, Melbourne
 Victoria 3168 Australia
 Tel: (3) 558-9999
 Fax: (3) 558-9998

National does not assume any responsibility for use of any circuitry described, no circuit patent licenses are implied and National reserves the right at any time without notice to change said circuitry and specifications.